



## IIT6000 Industrial-Grade Current Transducer

---

IIT6000 has a high gain and measurement accuracy in the full bandwidth range, due to the application of the multi-point zero-flux technology system and high-frequency ripple sensing channel on top of currently existing DC sensor technology.

The multi-point zero-flux technology system secures the high accuracy by utilizing the technology combination of exciting magnetic flux closed-loop control, self-excited magnetic flux gate and multi-closed-loop control that realizes the closed-loop control between excitation magnetic flux and AC/DC magnetic flux generated by primary current, while the high-frequency ripple sensing channel allows the sensor to have the high performance over the full bandwidth range.

### Product photo





## Key Technologies

- ◇ Excitation closed-loop control technology
- ◇ Self-excitation demagnetization technology
- ◇ Multi-point zero-flux technology
- ◇ Temperature control compensation technology
- ◇ Multi-range automatic switching technology

## Features

- ◇ Insulated measurement between primary and secondary side
- ◇ Excellent linearity and accuracy
- ◇ Extremely low temperature drift
- ◇ Extremely low zero drift
- ◇ Broad band and low response time
- ◇ Strong anti-electromagnetic interference

## Application Domain

- ◇ Medical Equipment: Scanner, MRI
- ◇ Power industry: Converter, Inverter □
- ◇ Renewable Energy: Photovoltaic, Wind energy □
- ◇ Testing Instrument: Power analyzer, High-precision power supply
- ◇ Rail Transit: EMU, Metro, Trolley car □
- ◇ Ship: Electric driven ship
- ◇ Car: Electric car

### SHENZHEN HANGZHI PRECISION ELECTRONICS CO.,LTD

Add: Rm 531, Building B, Huayuan Hi-Tech Innovation Park,  
Baoyuan Rd, Bao'an District, Shenzhen, China P.R.

Email: [sales@hangzhiprecision.com](mailto:sales@hangzhiprecision.com)

Tel: +86 (0)755 8259 3440

Technical Support: [support@hangzhiprecision.com](mailto:support@hangzhiprecision.com)

Website: [www.hangzhiprecision.com](http://www.hangzhiprecision.com)





- ◇ Smart Power Grid: Power generation and battery monitoring, Medium low voltage substation
- ◇ Industry Control: Industrial motor drive, UPS, Welding, Robot, Hoist, Elevator, Ski lift

## Electrical Performance

Parameter	Symbol	Measuring Conditions	Min	Typ	Max	Unit
Primary nominal direct current	$I_{PN\_DC}$	—	—	±6000	—	Adc
Primary nominal alternating current*	$I_{PN}$	—	—	4243	—	Aac
Primary overload current	$I_{PM}$	—	—	—	±6600	Adc
Operating voltage	$V_C$	—	—	220	—	Vac
Current ratio	$K_N$	Input : Output	6000:1	6000:1	6000:1	—
Rated output current	$I_{SN}$	Rated Primary current	—	±1.0	—	A
Secondary burden resistance	$R_M$		0	1	1.5	$\Omega$

\* refers to AC effective value

## Accuracy Measurement

Parameter	Symbol	Measuring Conditions	Min	Typ	Max	Unit
Accuracy	$X_G$	Input direct current, full temperature range	—	—	0.02	%
Linearity	$\epsilon_L$	Full temperature range	—	—	50	ppm
Zero offset current	$I_{OT}$	@25°C	—	—	±5	$\mu A$
Zero offset current	$I_O$	Full temperature range	—	—	±10	$\mu A$
Response time	$t_r$	$di/dt=100A/us$ , rised to 90% $I_{PN}$	—	—	1	us
Current change rate	$di/dt$	—	200	—	—	A/us

### SHENZHEN HANGZHI PRECISION ELECTRONICS CO.,LTD

Add: Rm 531, Building B, Huayuan Hi-Tech Innovation Park,  
Baoyuan Rd, Bao'an District, Shenzhen, China P.R.

Email: [sales@hangzhiprecision.com](mailto:sales@hangzhiprecision.com)

Technical Support: [support@hangzhiprecision.com](mailto:support@hangzhiprecision.com)

Tel: +86 (0)755 8259 3440

Website: [www.hangzhiprecision.com](http://www.hangzhiprecision.com)





Frequency bandwidth (-3dB)	F	—	0	—	100	kHz
----------------------------	---	---	---	---	-----	-----

## Safety Characteristics

Parameter	Symbol	Measuring Conditions	Value	Unit
Insulation voltage / Between primary and secondary sides	Vd	50Hz,1min	5	KV
Transient isolation withstand voltage / Between primary and secondary sides	Vw	50us	10	KV
Creepage distance / Between the primary and the outer shell	dCp	—	11	mm
Clearance distance / Between the primary and the outer shell	dCi	—	11	mm
Comparative tracking index	CTI	IEC-60112	600	V

## General Characteristics

Parameter	Symbol	Measuring Condition	Min	Typ	Max	Unit
Ambient operating temperature	T <sub>A</sub>	—	-40	—	+85	°C
Mass	M	—		27300±1000		g

## Operating Status Instructions

### ◇ Normal status:

The green light indicator is on when the device is running normally:

After the device is powered on, the green indicator is on when the device is running normally.

When the green light is off, you should check whether the power supply of the transducer is normal as the first step.

### SHENZHEN HANGZHI PRECISION ELECTRONICS CO.,LTD

Add: Rm 531, Building B, Huayuan Hi-Tech Innovation Park,

Baoyuan Rd, Bao'an District, Shenzhen, China P.R.

Email: [sales@hangzhiprecision.com](mailto:sales@hangzhiprecision.com)

Technical Support: [support@hangzhiprecision.com](mailto:support@hangzhiprecision.com)

Tel: +86 (0)755 8259 3440

Website: [www.hangzhiprecision.com](http://www.hangzhiprecision.com)





◇ Fault status :

The green light is blinking when the current overloads.

Trouble-shooting:

If the power supply is normal, the green light indicator keeps on blinking, then the primary current is over the specified measurement range and the transducer will be in overload mode. In this mode, the transducer will be working in non-zero flux mode, the secondary and primary currents are not in proportion. When the current recovers to the specified measurement current range, the current transducer returns to normal, green light indicator will be on.

## Instructions

The steps are as follows:

Step 1: Connect the transducer and the control box through a dedicated connection line.

Step 2: Insert the AC 220V power plug into the control box and turn on the power supply switch

Step 3: Pass the current cable to be tested through the transducer and pay attention to the current direction.

Step 4: The current output interface is connected to the current measuring instrument or current sampling circuit. Note that the sampling resistance value cannot exceed the maximum limit value.

## Connection System

1. Control box power supply wiring:

The power interface of the control box is directly connected to the 220V power supply;

Red terminal: the positive side of the secondary current output;

Black terminal: the negative side of the secondary current output;

2. Connection of control box and winding coil

Insert the D-Sub9 male connector on the winding coil directly into the D-Sub9 female connector of the control box and fix it with screws.

3. Test description:

By measuring the test current  $I_S$  flowing through  $R_M$ , or the voltage  $U_R$  across  $R_M$ ,

The primary current  $I_P$  can be obtained:

$$I_P = K_N * I_S = K_N * (U_R / R_M)$$

## Dimensions

**SHENZHEN HANGZHI PRECISION ELECTRONICS CO.,LTD**

Add: Rm 531, Building B, Huayuan Hi-Tech Innovation Park,

Baoyuan Rd, Bao'an District, Shenzhen, China P.R.

Email: [sales@hangzhiprecision.com](mailto:sales@hangzhiprecision.com)

Tel: +86 (0)755 8259 3440

Technical Support: [support@hangzhiprecision.com](mailto:support@hangzhiprecision.com)

Website: [www.hangzhiprecision.com](http://www.hangzhiprecision.com)





Unit: mm

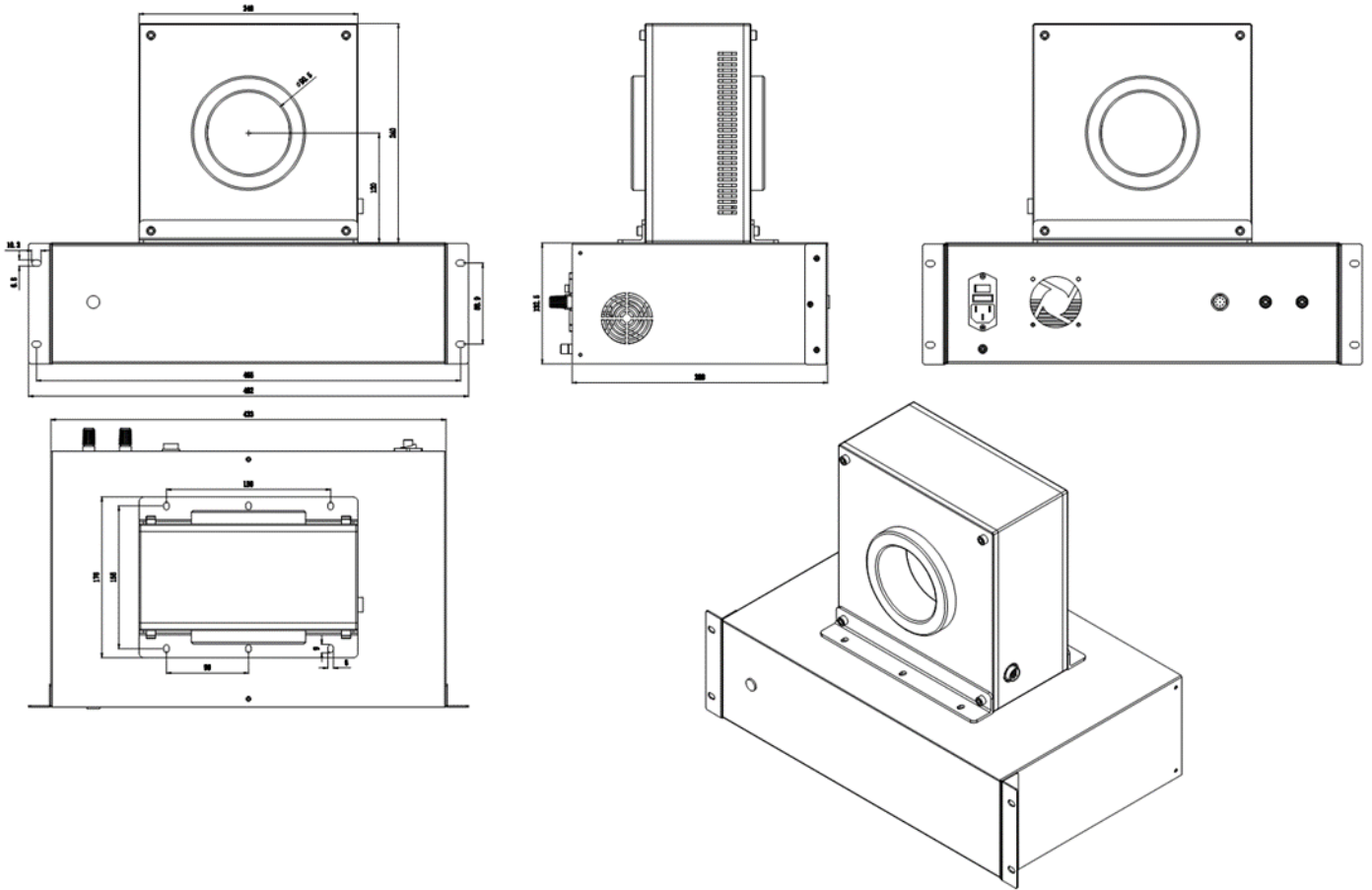

**SHENZHEN HANGZHI PRECISION ELECTRONICS CO.,LTD**

Add: Rm 531, Building B, Huayuan Hi-Tech Innovation Park,  
Baoyuan Rd, Bao'an District, Shenzhen, China P.R.

Email: [sales@hangzhiprecision.com](mailto:sales@hangzhiprecision.com)

Technical Support: [support@hangzhiprecision.com](mailto:support@hangzhiprecision.com)

Tel: +86 (0)755 8259 3440

Website: [www.hangzhiprecision.com](http://www.hangzhiprecision.com)

