



IIT600 Industrial-Grade Current Transducer

IIT600 has a high gain and measurement accuracy in the full bandwidth range, due to the application of the multi-point zero-flux technology system and high-frequency ripple sensing channel on top of currently existing DC sensor technology.

The multi-point zero-flux technology system secures the high accuracy by utilizing the technology combination of exciting magnetic flux closed-loop control, self-excited magnetic flux gate and multi-closed-loop control that realizes the closed-loop control between excitation magnetic flux and AC/DC magnetic flux generated by primary current, while the high-frequency ripple sensing channel allows the sensor to have the high performance over the full bandwidth range.

Product photo





Key Technologies

- ◇ Excitation closed-loop control technology
- ◇ Self-excitation demagnetization technology
- ◇ Multi-point zero-flux technology
- ◇ Temperature control compensation technology
- ◇ Multi-range automatic switching technology

Features

- ◇ Insulated measurement between primary and secondary side
- ◇ Excellent linearity and accuracy
- ◇ Extremely low temperature drift
- ◇ Extremely low zero drift
- ◇ Broad band and low response time
- ◇ Strong anti-electromagnetic interference

Application Domain

- ◇ Medical Equipment: Scanner, MRI
- ◇ Power industry: Converter, Inverter □
- ◇ Renewable Energy: Photovoltaic, Wind energy □
- ◇ Testing Instrument: Power analyzer, High-precision power supply
- ◇ Rail Transit: EMU, Metro, Trolley car □
- ◇ Ship: Electric driven ship
- ◇ Car: Electric car

SHENZHEN HANGZHI PRECISION ELECTRONICS CO.,LTD

Add: Rm 531, Building B, Huayuan Hi-Tech Innovation Park, Baoyuan Rd, Bao'an District, Shenzhen, China P.R.

Email: sales@hangzhiprecision.com

Tel: +86 (0)755 8259 3440

Technical Support: support@hangzhiprecision.com

Website: www.hangzhiprecision.com





- ◇ Smart Power Grid: Power generation and battery monitoring, Medium low voltage substation
- ◇ Industry Control: Industrial motor drive, UPS, Welding, Robot, Hoist, Elevator, Ski lift

Electrical Performance

Parameter	Symbol	Measuring Conditions	Min	Typ	Max	Unit
Primary nominal direct current	I_{PN_DC}	—	—	±600	—	Adc
Primary nominal alternating current*	I_{PN}	—	—	424	—	Aac
Primary overload current	I_{PM}	1 Minute	—	—	±720	Adc
Operating voltage	V_C	—	±14.2	±15	±15.8	V
Power consumption current	I_{PWR}	Rated primary current	±30	±430	±510	mA
Current ratio	K_N	Input : Output	1500:1	1500:1	1500:1	—
Rated output current	I_{SN}	Rated Primary current	—	0.4	—	A
Secondary burden resistance	R_M	—	0	2	5	Ω

* refers to AC effective value

Accuracy Measurement

Parameter	Symbol	Measuring Conditions	Min	Typ	Max	Unit
Accuracy	X_G	Input direct current, full temperature range	—	—	0.02	%
Linearity	ϵ_L	Full temperature range	—	—	20	ppm
Zero offset current	I_{OT}	@25°C	—	—	±5	μA
Zero offset current	I_O	Full temperature range	—	—	±10	μA
Response time	t_r	$di/dt=100A/us$, rised to 90% I_{PN}	—	—	1	us
Current change rate	di/dt	—	200	—	—	A/us

SHENZHEN HANGZHI PRECISION ELECTRONICS CO.,LTD

Add: Rm 531, Building B, Huayuan Hi-Tech Innovation Park,
Baoyuan Rd, Bao'an District, Shenzhen, China P.R.

Email: sales@hangzhiprecision.com

Tel: +86 (0)755 8259 3440

Technical Support: support@hangzhiprecision.com

Website: www.hangzhiprecision.com





Frequency bandwidth (-3dB)	F	—	0	—	100	kHz
----------------------------	---	---	---	---	-----	-----

Safety Characteristics

Parameter	Symbol	Measuring Conditions	Value	Unit
Insulation voltage / Between primary and secondary sides	Vd	50Hz,1min	5	KV
Transient isolation withstand voltage / Between primary and secondary sides	Vw	50us	10	KV
Creepage distance / Between the primary and the outer shell	dCp	—	11	mm
Clearance distance / Between the primary and the outer shell	dCi	—	11	mm
Comparative tracking index	CTI	IEC-60112	600	V

General Characteristics

Parameter	Symbol	Measuring Condition	Min	Typ	Max	Unit
Ambient operating temperature	T _A	—	-40	—	+85	°C
Ambient storage temperature	T _S	—	-55	—	+95	°C
Relative humidity	RH	—	20	—	80	%
Mass	M	—		1000±80		g

Operating Status Instructions

◇ Normal status:

The green light indicator is on when the device is running normally:

SHENZHEN HANGZHI PRECISION ELECTRONICS CO.,LTD

Add: Rm 531, Building B, Huayuan Hi-Tech Innovation Park,

Baoyuan Rd, Bao'an District, Shenzhen, China P.R.

Email: sales@hangzhiprecision.com

Tel: +86 (0)755 8259 3440

Technical Support: support@hangzhiprecision.com

Website: www.hangzhiprecision.com





After the device is powered on, the green indicator is on when the device is running normally. When the green light is off, you should check whether the power supply of the transducer is normal as the first step.

◇ Fault status:

The green light is blinking when the current overloads.

Trouble-shooting:

If the power supply is normal, the green light indicator keeps on blinking, then the primary current is over the specified measurement range and the transducer will be in overload mode. In this mode, the transducer will be working in non-zero flux mode, the secondary and primary currents are not in proportion. When the current recovers to the specified measurement current range, the current transducer returns to normal, green light indicator will be on.

Connection system

1. Phoenix terminal pin function definition

Pin	1	2	3	4
Definition	+15V Supply	-15V Supply	I_Output	GND

IIT Series Transducer

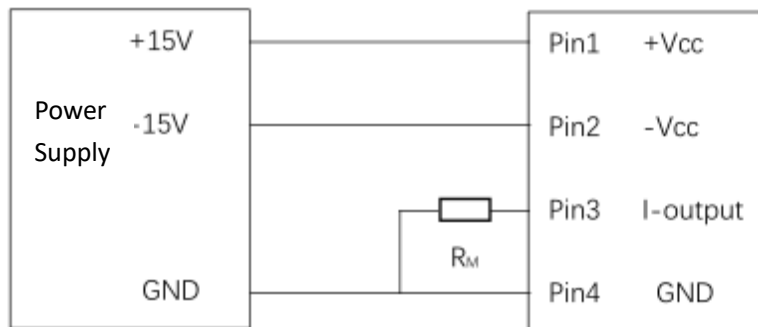

Test instruction:

The primary current I_P can be obtained by measuring the test current I_S flowing through R_M or the voltage U_R across R_M:

$$I_P = K_N * I_S = K_N * (U_R / R_M)$$



Dimensions

Unit: mm

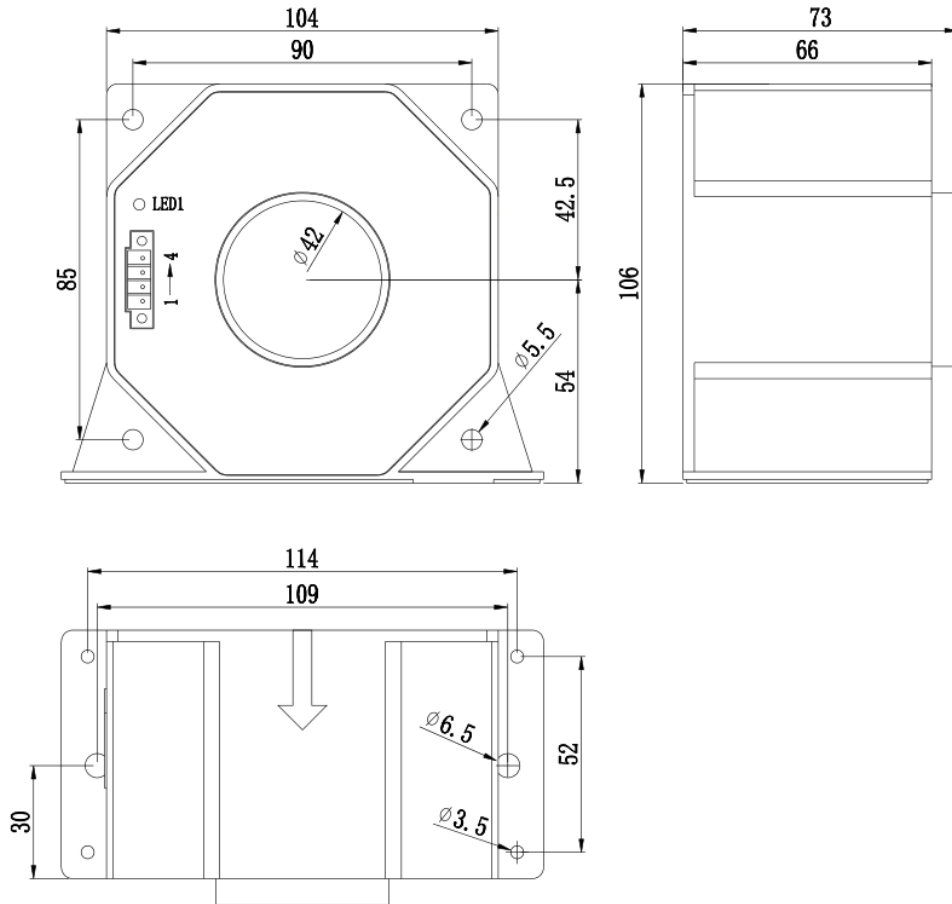

SHENZHEN HANGZHI PRECISION ELECTRONICS CO.,LTD

Add: Rm 531, Building B, Huayuan Hi-Tech Innovation Park,
Baoyuan Rd, Bao'an District, Shenzhen, China P.R.

Email: sales@hangzhiprecision.com

Tel: +86 (0)755 8259 3440

Technical Support: support@hangzhiprecision.com

Website: www.hangzhiprecision.com

