

IIT100 Industrial-Grade Current Transducer

IIT100 has a high gain and measurement accuracy in the full bandwidth range, due to the application of the multi-point zero-flux technology system and high-frequency ripple sensing channel on top of currently existing DC sensor technology.

The multi-point zero-flux technology system secures the high accuracy by utilizing the technology combination of exciting magnetic flux closed-loop control, self-excited magnetic flux gate and multi-closed-loop control that realizes the closed-loop control between excitation magnetic flux and AC/DC magnetic flux generated by primary current, while the high-frequency ripple sensing channel allows the sensor to have the high performance over the full bandwidth range.

Product photo



SHENZHEN HANGZHI PRECISION ELECTRONICS CO.,LTD

Add: Rm 531, Building B, Huayuan Hi-Tech Innovation Park,
Baoyuan Rd, Bao'an District, Shenzhen, China P.R.

Email: sales@hangzhiprecision.com

Tel: +86 (0)755 8259 3440

Technical Support: support@hangzhiprecision.com

Website: www.hangzhiprecision.com





Key Technologies

- ◇ Excitation closed-loop control technology
- ◇ Self-excitation demagnetization technology
- ◇ Multi-point zero-flux technology
- ◇ Temperature control compensation technology
- ◇ Multi-range automatic switching technology

Features

- ◇ Insulated measurement between primary and secondary side
- ◇ Excellent linearity and accuracy
- ◇ Extremely low temperature drift
- ◇ Extremely low zero drift
- ◇ Broad band and low response time
- ◇ Strong anti-electromagnetic interference

Application Domain

- ◇ Medical Equipment: Scanner, MRI
- ◇ Power industry: Converter, Inverter □
- ◇ Renewable Energy: Photovoltaic, Wind energy □
- ◇ Testing Instrument: Power analyzer, High-precision power supply
- ◇ Smart Power Grid: Power generation and battery monitoring, Medium low voltage substation
- ◇ Industry Control: Industrial motor drive, UPS, Welding, Robot, Hoist, Elevator, Ski lift
- ◇ Rail Transit: EMU, Metro, Trolley car □
- ◇ Ship: Electric driven ship
- ◇ Car: Electric car

Electrical Performance

Parameter	Symbol	Measuring Conditions	Min	Typ	Max	Unit
Primary nominal direct current	I_{PN_DC}	—	—	±100	—	Adc
Primary nominal alternating current*	I_{PN}	—	—	70.7	—	Aac
Primary overload current	I_{PM}	1 Minute	—	—	±120	Adc
Operating voltage	V_C	—	±14.2	±15	±15.8	V
Power consumption current	I_{PWR}	Rated primary current	±30	±130	±150	mA
Current ratio	K_N	Input : Output	1000:1	1000:1	1000:1	—
Rated output current	I_{SN}	Rated Primary current	—	±0.1	—	A
Secondary burden resistance	R_M	See Fig. 1	0	10	50	Ω

* refers to AC effective value



Accuracy Measurement

Parameter	Symbol	Measuring Conditions	Min	Typ	Max	Unit
Accuracy	X _G	Input direct current, full temperature range	—	—	0.02	%
Linearity	ε _L	Full temperature range	—	—	20	ppm
Zero offset current	I _{OT}	@25°C	—	—	±5	μA
Zero offset current	I _O	Full temperature range	—	—	±10	μA
Response time	t _r	di/dt=100A/us, rised to 90%I _{PN}	—	—	1	us
Current change rate	di/dt	—	200	—	—	A/us
Frequency bandwidth (-3dB)	F	—	0	—	100	kHz

Safety Characteristics

Parameter	Symbol	Measuring Conditions	Value	Unit
Insulation voltage / Between primary and secondary sides	V _d	50Hz, 1min	5	KV
Transient isolation withstand voltage / Between primary and secondary sides	V _w	50us	10	KV
Creepage distance / Between the primary and the outer shell	dC _p	—	11	mm
Clearance distance / Between the primary and the outer shell	dC _i	—	11	mm
Comparative tracking index	CTI	IEC-60112	600	V

General Characteristics

Parameter	Symbol	Measuring Condition	Min	Typ	Max	Unit
Ambient operating temperature	T _A	—	-40	—	+85	°C
Ambient storage temperature	T _S	—	-55	—	+95	°C
Relative humidity	RH	—	20	—	80	%
Mass	M	—	—	370±50	—	g

SHENZHEN HANGZHI PRECISION ELECTRONICS CO.,LTD

Add: Rm 531, Building B, Huayuan Hi-Tech Innovation Park,
Baoyuan Rd, Bao'an District, Shenzhen, China P.R.

Email: sales@hangzhiprecision.com

Tel: +86 (0)755 8259 3440

Technical Support: support@hangzhiprecision.com

Website: www.hangzhiprecision.com





Operating Status Instructions

◇ Normal status:

The green light indicator is on when the device is running normally:

After the device is powered on, the green indicator is on when the device is running normally.

When the green light is off, you should check whether the power supply of the transducer is normal as the first step.

◇ Fault status:

The green light is blinking when the current overloads.

Trouble-shooting:

If the power supply is normal, the green light indicator keeps on blinking, then the primary current is over the specified measurement range and the transducer will be in overload mode. In this mode, the transducer will be working in non-zero flux mode, the secondary and primary currents are not in proportion. When the current recovers to the specified measurement current range, the current transducer returns to normal, green light indicator will be on.

Connection system

1. Phoenix terminal pin function definition

Pin	1	2	3	4
Definition	+15V Supply	-15V Supply	I_Output	GND

IIT Series Transducer

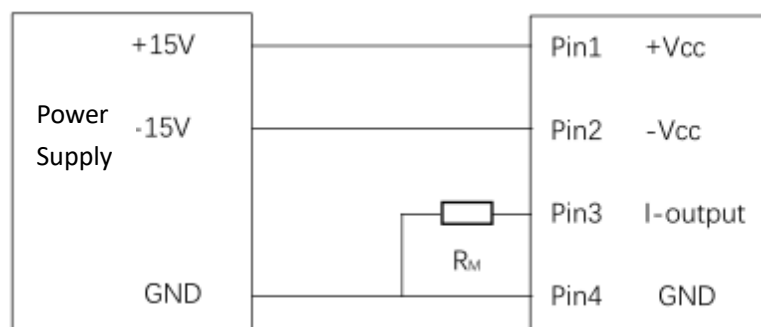



Test instruction :

The primary current I_P can be obtained by measuring the test current I_S flowing through R_M or the voltage U_R across R_M :

$$I_P = K_N * I_S = K_N * (U_R/R_M)$$

Dimensions

Unit: mm

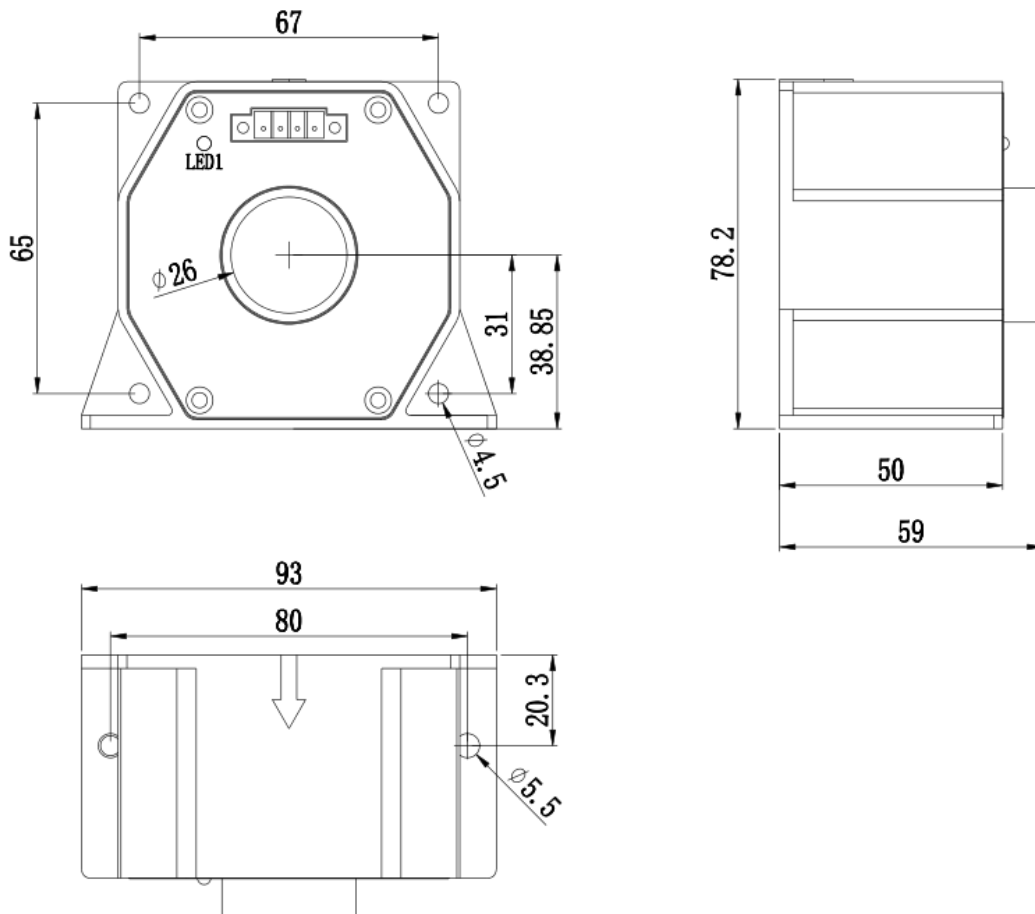

SHENZHEN HANGZHI PRECISION ELECTRONICS CO.,LTD

Add: Rm 531, Building B, Huayuan Hi-Tech Innovation Park,
Baoyuan Rd, Bao'an District, Shenzhen, China P.R.

Email: sales@hangzhiprecision.com

Tel: +86 (0)755 8259 3440

Technical Support: support@hangzhiprecision.com

Website: www.hangzhiprecision.com





SHENZHEN HANGZHI PRECISION ELECTRONICS CO.,LTD

Add: Rm 531, Building B, Huayuan Hi-Tech Innovation Park,
Baoyuan Rd, Bao'an District, Shenzhen, China P.R.

Email: sales@hangzhiprecision.com

Technical Support: support@hangzhiprecision.com

Tel: +86 (0)755 8259 3440

Website: www.hangzhiprecision.com

