



HIT50 Hall-Substituting Current Transducer

HIT50 has a high gain and measurement accuracy in the full bandwidth range, due to the application of the multi-point zero-flux technology system and high-frequency ripple sensing channel on top of currently existing DC sensor technology.

The multi-point zero-flux technology system secures the high accuracy by utilizing the technology combination of exciting magnetic flux closed-loop control, self-excited magnetic flux gate and multi-closed-loop control that realizes the closed-loop control between excitation magnetic flux and AC/DC magnetic flux generated by primary current, while the high-frequency ripple sensing channel allows the sensor to have the high performance over the full bandwidth range.

Product photo



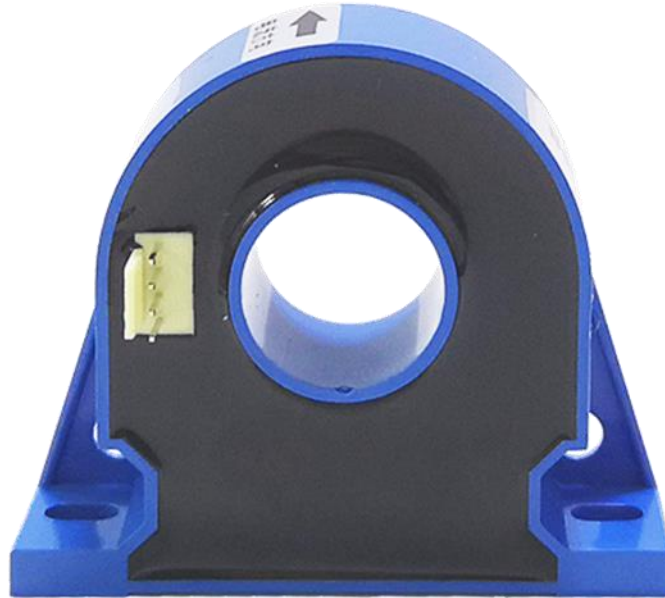

Key Technologies

- ◇ Excitation closed-loop control technology
- ◇ Self-excitation demagnetization technology
- ◇ Multi-point zero-flux technology
- ◇ Temperature control compensation technology
- ◇ Multi-range automatic switching technology

Features

- ◇ Insulated measurement between primary and secondary side
- ◇ Excellent linearity and accuracy
- ◇ Extremely low temperature drift
- ◇ Extremely low zero drift
- ◇ Broad bandwidth and short response time
- ◇ Strong anti-electromagnetic interference

Application Domain

- ◇ Medical Equipment: Scanner, MRI
- ◇ Power industry: Converter, Inverter □
- ◇ Renewable Energy: Photovoltaic, Wind energy □
- ◇ Testing Instrument: Power analyzer, High-precision power supply
- ◇ Smart Power Grid: Power generation and battery monitoring, Medium low voltage substation
- ◇ Industry Control: Industrial motor drive, UPS, Welding, Robot, Hoist, Elevator, Ski lift
- ◇ Rail Transit: EMU, Metro, Trolley car □
- ◇ Ship: Electric driven ship
- ◇ Car: Electric car

SHENZHEN HANGZHI PRECISION ELECTRONICS CO.,LTD

Add: Rm 531, Building B, Huayuan Hi-Tech Innovation Park,
Baoyuan Rd, Bao'an District, Shenzhen, China P.R.

Email: sales@hangzhiprecision.com

Tel: +86 (0)755 8259 3440

Technical Support: support@hangzhiprecision.com

Website: www.hangzhiprecision.com





Electrical Performance

| Parameter | Symbol | Measuring Conditions | Min | Typ | Max | Unit |
|--------------------------------------|--------------|-----------------------|--------|--------|--------|----------|
| Primary nominal direct current | I_{PN_DC} | — | — | ±50 | — | Adc |
| Primary nominal alternating current* | I_{PN} | — | — | 35 | — | Aac |
| Primary overload current | I_{PM} | 1 Minute | — | — | ±60 | Adc |
| Operating voltage | V_C | — | ±14.2 | ±15 | ±15.8 | V |
| Power consumption current | I_{PWR} | Rated primary current | ±30 | ±80 | ±180 | mA |
| Current ratio | K_N | Input : Output | 1000:1 | 1000:1 | 1000:1 | — |
| Rated output current | I_{SN} | Rated primary current | — | ±0.05 | — | A |
| Secondary burden resistance | R_M | See Fig. 1 | 0 | 20 | 50 | Ω |

* refers to AC effective value

Accuracy Measurement

| Parameter | Symbol | Measuring Conditions | Min | Typ | Max | Unit |
|-------------------------|--------------|--|-----|-----|-----|------------|
| Accuracy | X_G | Input direct current, full temperature range | — | — | 500 | ppm |
| Linearity | ϵ_L | Full scale | — | — | 50 | ppm |
| Temperature Coefficient | T_C | — | — | — | 50 | ppm/K |
| Zero offset current | I_O | @25°C | — | — | ±5 | μA |
| Zero offset current | I_{OT} | Full temperature range | — | — | ±10 | μA |
| Dynamic response time | t_r | $di/dt=100A/\mu s$, rised to 90% I_{PN} | — | 1 | — | μs |
| Current change rate | di/dt | — | 100 | — | — | A/ μs |

SHENZHEN HANGZHI PRECISION ELECTRONICS CO.,LTD

Add: Rm 531, Building B, Huayuan Hi-Tech Innovation Park,
Baoyuan Rd, Bao'an District, Shenzhen, China P.R.

Email: sales@hangzhiprecision.com

Tel: +86 (0)755 8259 3440

Technical Support: support@hangzhiprecision.com

Website: www.hangzhiprecision.com





Frequency bandwidth F — 0 — 100 kHz

Safety Characteristics

| Parameter | Symbol | Measuring Conditions | Value | Unit |
|---|--------|----------------------|-------|------|
| Insulation voltage / Between primary and secondary sides | Vd | 50Hz,1min | 5 | KV |
| Transient isolation withstand voltage / Between primary and secondary sides | Vw | 50us | 10 | KV |
| Creepage distance / Between the primary and the outer shell | dCp | — | 11 | mm |
| Clearance distance / Between the primary and the outer shell | dCi | — | 11 | mm |
| Comparative tracking index | CTI | IEC-60112 | 275 | V |

General Characteristics

| Parameter | Symbol | Measuring Condition | Min | Typ | Max | Unit |
|-------------------------------|----------------|---------------------|-----|-------|-----|------|
| Ambient operating temperature | T _A | — | -40 | — | +80 | °C |
| Storage temperature range | T _s | — | -55 | — | +95 | °C |
| Relative humidity | RH | — | 20 | — | 80 | % |
| Mass | M | — | — | 80±10 | — | g |

Operating Status Instructions

When power supply is normal and the primary current is within the specified measurement range, the secondary and primary currents are in proportional. If the primary current is over the specified measurement range, the transducers will be in overload mode, and the secondary and primary currents

SHENZHEN HANGZHI PRECISION ELECTRONICS CO.,LTD

Add: Rm 531, Building B, Huayuan Hi-Tech Innovation Park,
Baoyuan Rd, Bao'an District, Shenzhen, China P.R.

Email: sales@hangzhiprecision.com

Tel: +86 (0)755 8259 3440

Technical Support: support@hangzhiprecision.com

Website: www.hangzhiprecision.com



are not in proportional. The secondary and primary currents will return to be in proportional when the primary current recovers to the specified measurement range.

Connection system

1. Pin function definition of phoenix terminal

| Pin No. | 1 V+ | 2 V- | 3 OUT | 4 GND |
|------------|--------------------|--------------------|-----------------|------------|
| Definition | +15V Supply | -15V Supply | I_Output | GND |

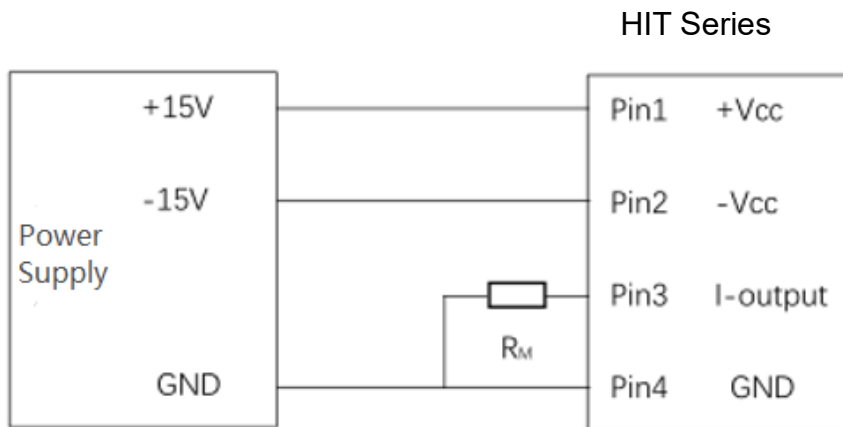

Test instruction:

The primary current I_P can be obtained by measuring the test current I_S flowing through R_M or the voltage U_R across R_M :

$$I_P = K_N * I_S = K_N * (U_R / R_M)$$

Dimensions

SHENZHEN HANGZHI PRECISION ELECTRONICS CO.,LTD

Add: Rm 531, Building B, Huayuan Hi-Tech Innovation Park,
Baoyuan Rd, Bao'an District, Shenzhen, China P.R.

Email: sales@hangzhiprecision.com

Tel: +86 (0)755 8259 3440

Technical Support: support@hangzhiprecision.com

Website: www.hangzhiprecision.com



Unit: mm

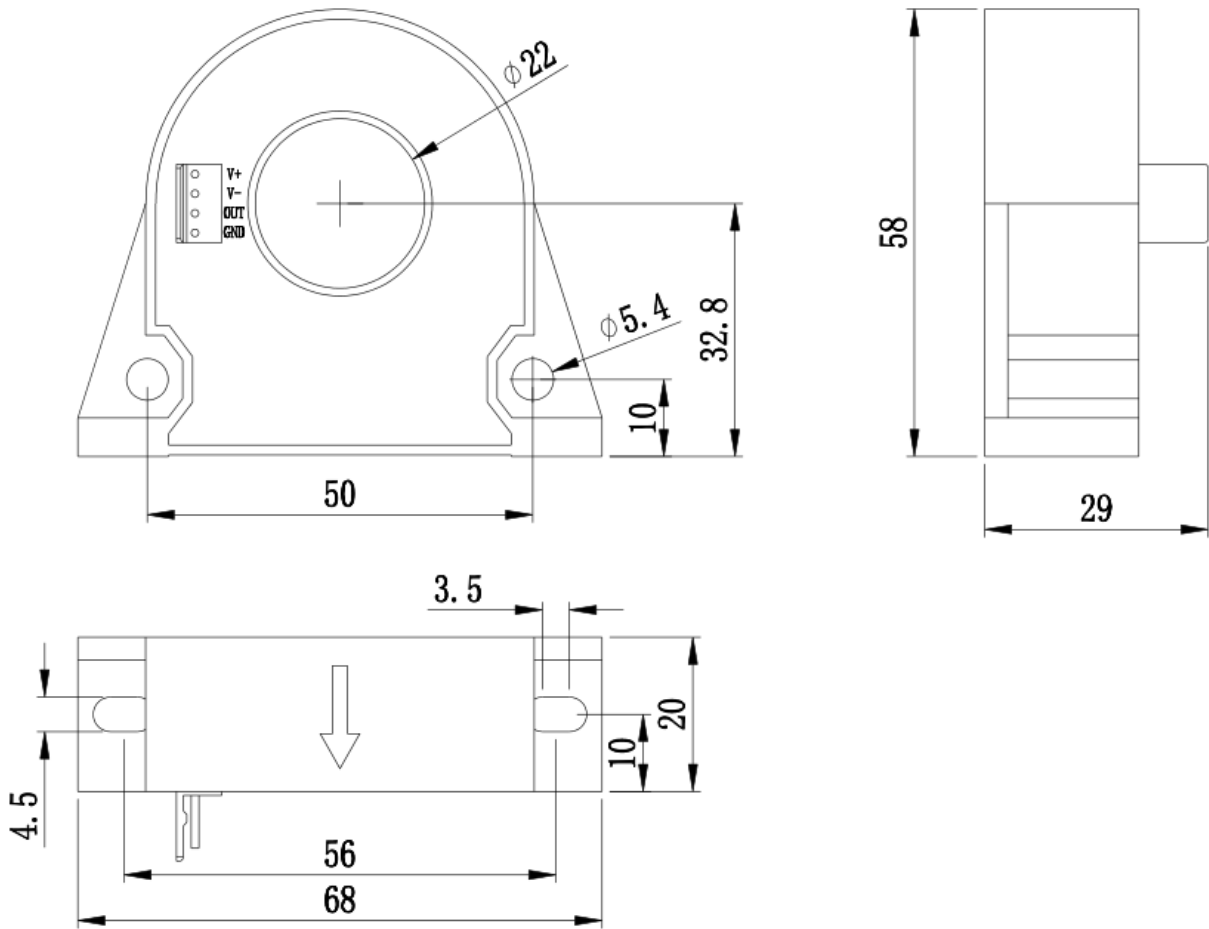

SHENZHEN HANGZHI PRECISION ELECTRONICS CO.,LTD

Add: Rm 531, Building B, Huayuan Hi-Tech Innovation Park,
Baoyuan Rd, Bao'an District, Shenzhen, China P.R.

Email: sales@hangzhiprecision.com

Technical Support: support@hangzhiprecision.com

Tel: +86 (0)755 8259 3440

Website: www.hangzhiprecision.com

