

AIT1000-SG High-Precision Current Transducer

AIT1000-SG has a high gain and measurement accuracy in the full bandwidth range, due to the application of the multi-point zero-flux technology system and high-frequency ripple sensing channel on top of currently existing DC sensor technology.

The multi-point zero-flux technology system secures the high accuracy by utilizing the technology combination of exciting magnetic flux closed-loop control, self-excited magnetic flux gate and multi-closed-loop control that realizes the closed-loop control between excitation magnetic flux and AC/DC magnetic flux generated by primary current, while the high-frequency ripple sensing channel allows the sensor to have the high performance over the full bandwidth range.

Product photo



SHENZHEN HANGZHI PRECISION ELECTRONICS CO.,LTD

Add: Rm 531, Building B, Huayuan Hi-Tech Innovation Park,
Baoyuan Rd, Bao'an District, Shenzhen, China P.R.

Email: sales@hangzhiprecision.com

Tel: +86 (0)755 8259 3440

Technical Support: support@hangzhiprecision.com

Website: www.hangzhiprecision.com





Key Technologies

- ◇ Excitation closed-loop control technology
- ◇ Self-excitation demagnetization technology
- ◇ Multi-point zero-flux technology
- ◇ Temperature control compensation technology
- ◇ Multi-range automatic switching technology

Features

- ◇ Insulated measurement between primary and secondary side
- ◇ Excellent linearity and accuracy
- ◇ Extremely low temperature drift
- ◇ Extremely low zero drift
- ◇ Broad band and low response time
- ◇ Strong anti-electromagnetic interference

Application Domain

- ◇ Medical Equipment: Scanner, MRI
- ◇ Power industry: Converter, Inverter □
- ◇ Renewable Energy: Photovoltaic, Wind energy □
- ◇ Testing Instrument: Power analyzer, High-precision power supply
- ◇ Smart Power Grid: Power generation and battery monitoring, Medium low voltage substation
- ◇ Industry Control: Industrial motor drive, UPS, Welding, Robot, Hoist, Elevator, Ski lift
- ◇ Rail Transit: EMU, Metro, Trolley car □
- ◇ Ship: Electric driven ship
- ◇ Car: Electric car

Electrical Performance

Parameter	Symbol	Measuring Conditions	Min	Typ	Max	Unit
Primary nominal direct current	I_{PN_DC}	—	—	±1000	—	Adc
Primary nominal alternating current*	I_{PN}	—	—	707	—	Aac
Primary overload current	I_{PM}	1 Minute	—	—	±1200	Adc
Operating voltage	V_C	—	±14.2	±15	±15.8	V
Power consumption current	I_{PWR}	Rated primary current	±30	±700	±830	mA
Current ratio	K_N	Input : Output	1500:1	1500:1	1500:1	—
Rated output current	I_{SN}	Rated Primary current	—	±0.67	—	A
Secondary burden resistance	R_M	See Fig. 1	0	1.5	3	Ω

* refers to AC effective value

SHENZHEN HANGZHI PRECISION ELECTRONICS CO.,LTD

Add: Rm 531, Building B, Huayuan Hi-Tech Innovation Park, Baoyuan Rd, Bao'an District, Shenzhen, China P.R.

Email: sales@hangzhiprecision.com

Tel: +86 (0)755 8259 3440

Technical Support: support@hangzhiprecision.com

Website: www.hangzhiprecision.com





Accuracy Measurement

Parameter	Symbol	Measuring Conditions	Min	Typ	Max	Unit
Accuracy	X _G	Input direct current, 25±10°C	—	—	10	ppm
Linearity	ε _L	—	—	—	2	ppm
Temperature stability	T _C	—	—	—	0.1	ppm/K
Time stability	T _T	—	—	—	0.2	ppm/month
Power supply interference	T _V	—	—	—	1	ppm/V
Zero offset current	I _O	@25°C	—	—	1 (can be adjusted to zero by users)	ppm
Ripple current	I _N	DC-10Hz	—	—	0.5	ppm
Dynamic response time	t _r	di/dt=100A/us, rised to 90%I _{PN}	—	—	1	us
Current change rate	di/dt	—	200	—	—	A/us
Frequency bandwidth (-3dB)	F	—	0	—	500	kHz
Zero offset current	I _{OT}	Full temperature range	—	—	±5	μA

Safety Characteristics

Parameter	Symbol	Measuring Conditions	Value	Unit
Insulation voltage / Between primary and secondary sides	V _d	50Hz, 1min	5	KV
Transient isolation withstand voltage / Between primary and secondary sides	V _w	50us	10	KV
Creepage distance / Between the primary and the outer shell	d _{Cp}	—	11	mm
Clearance distance / Between the primary and the outer shell	d _{CI}	—	11	mm
Comparative tracking index	CTI	IEC-60112	600	V

General Characteristics

SHENZHEN HANGZHI PRECISION ELECTRONICS CO.,LTD

Add: Rm 531, Building B, Huayuan Hi-Tech Innovation Park, Baoyuan Rd, Bao'an District, Shenzhen, China P.R.

Email: sales@hangzhiprecision.com

Tel: +86 (0)755 8259 3440

Technical Support: support@hangzhiprecision.com

Website: www.hangzhiprecision.com





Parameter	Symbol	Measuring Condition	Min	Typ	Max	Unit
Ambient operating temperature	T _A	—	-40	—	+85	°C
Mass	M	—		1150±80		g

Burden Resistor Instructions

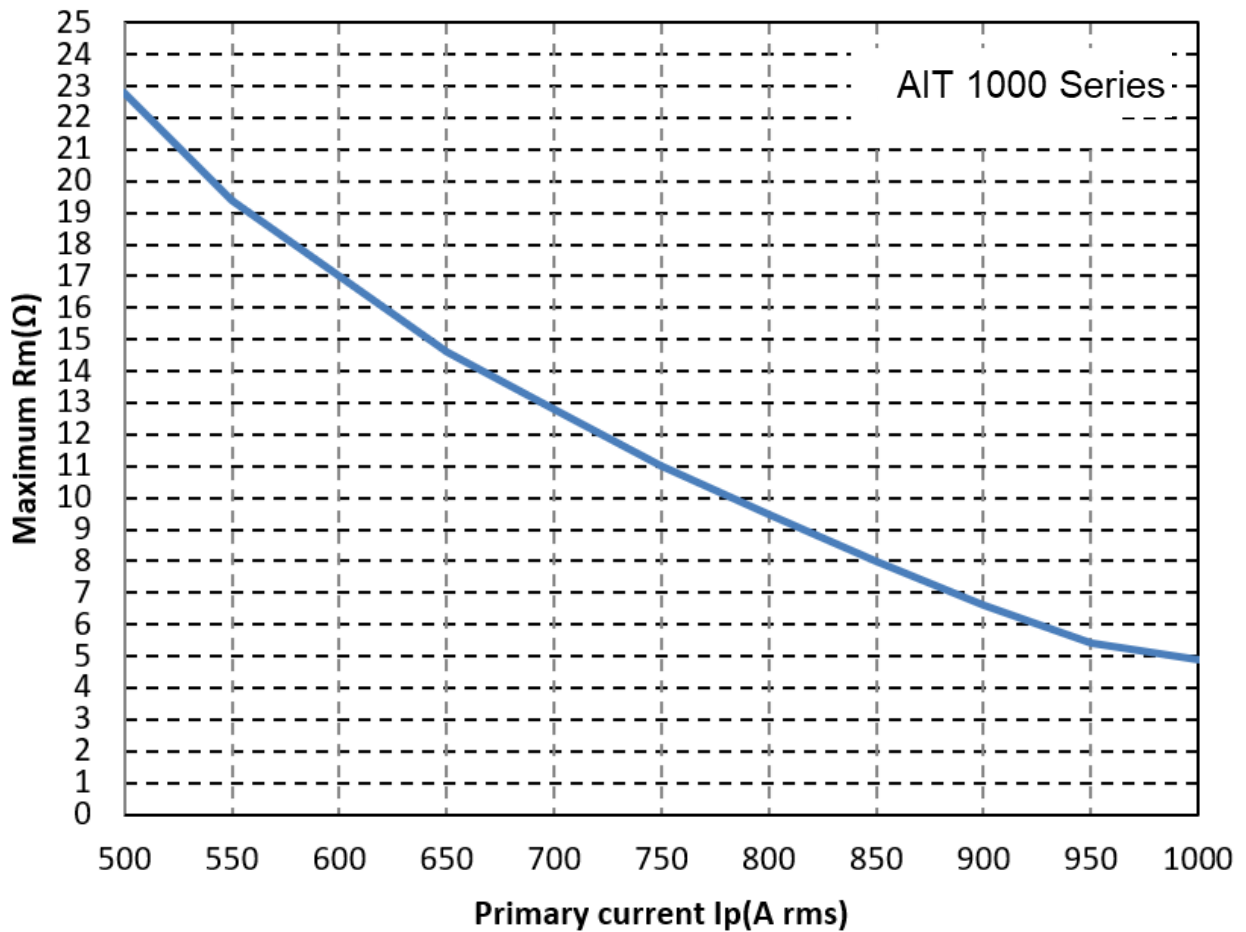

SHENZHEN HANGZHI PRECISION ELECTRONICS CO.,LTD

Add: Rm 531, Building B, Huayuan Hi-Tech Innovation Park, Baoyuan Rd, Bao'an District, Shenzhen, China P.R.

Email: sales@hangzhiprecision.com

Tel: +86 (0)755 8259 3440

Technical Support: support@hangzhiprecision.com

Website: www.hangzhiprecision.com





Operating Status Instructions

◇ Normal status:

The green indicator is on when the device is running normally:

After the device is powered on, the green indicator is on when the device is running normally, and the 3rd pin and 8th pin of D-Sub9 interface are connected together.

◇ Fault status:

The green light will be off when the transducer is in fault mode.

Trouble-shooting:

a) When the green light is off, the power supply should be checked as the first step;

b) If the power supply is normal, then the primary current is over the specified measurement range and the transducers will be in overload mode.

In this mode, the transducers will be working in non-zero flux mode, that the secondary current remains at specified maximum output, the secondary and primary currents are not in proportional and the connection between pin 3 & 8 of the DB9 interface will be off.

Connection system

1. D-Sub9 Connection terminal pin function definition

Pin No.	1	2、7	3	4	5	6	8	9
Definition	I_Output COM	N.C	Interlock(-)	GND	-15V Supply	I_Output	Interlock(+)	+15V Supply

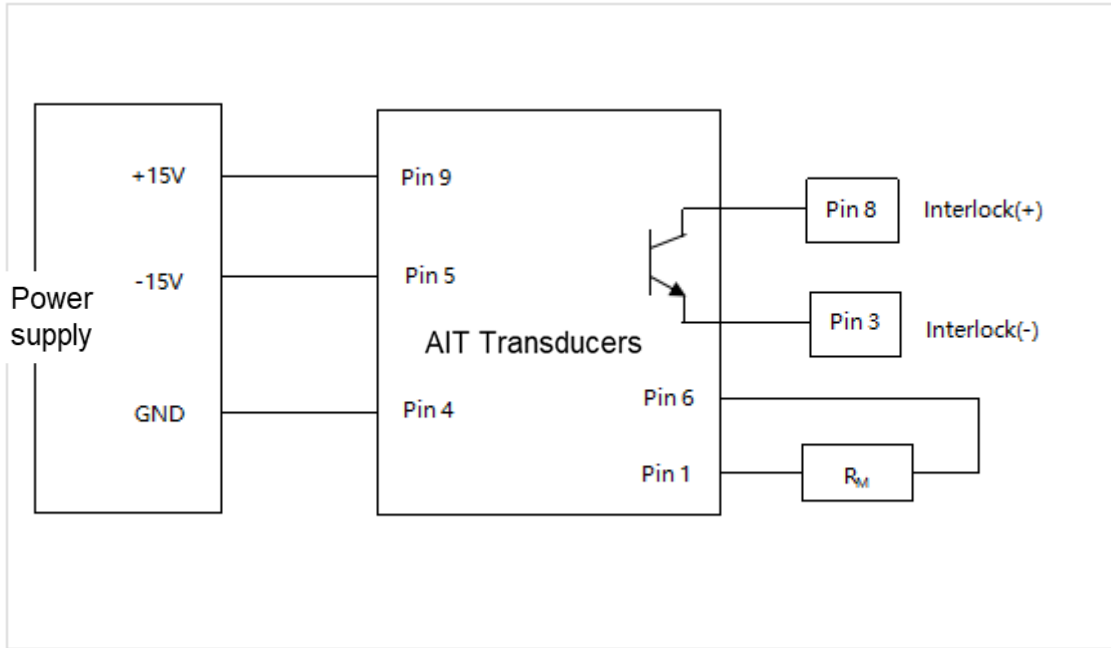

Test instruction :

The primary current I_P can be obtained by measuring the test current I_S flowing through R_M or the voltage U_R across R_M :

$$I_P = K_N * I_S = K_N * (U_R/R_M)$$

2. Interlock Port connection description :

There are two types of Interlock Port connection based on users' actual application shown as Fig A and Fig B:

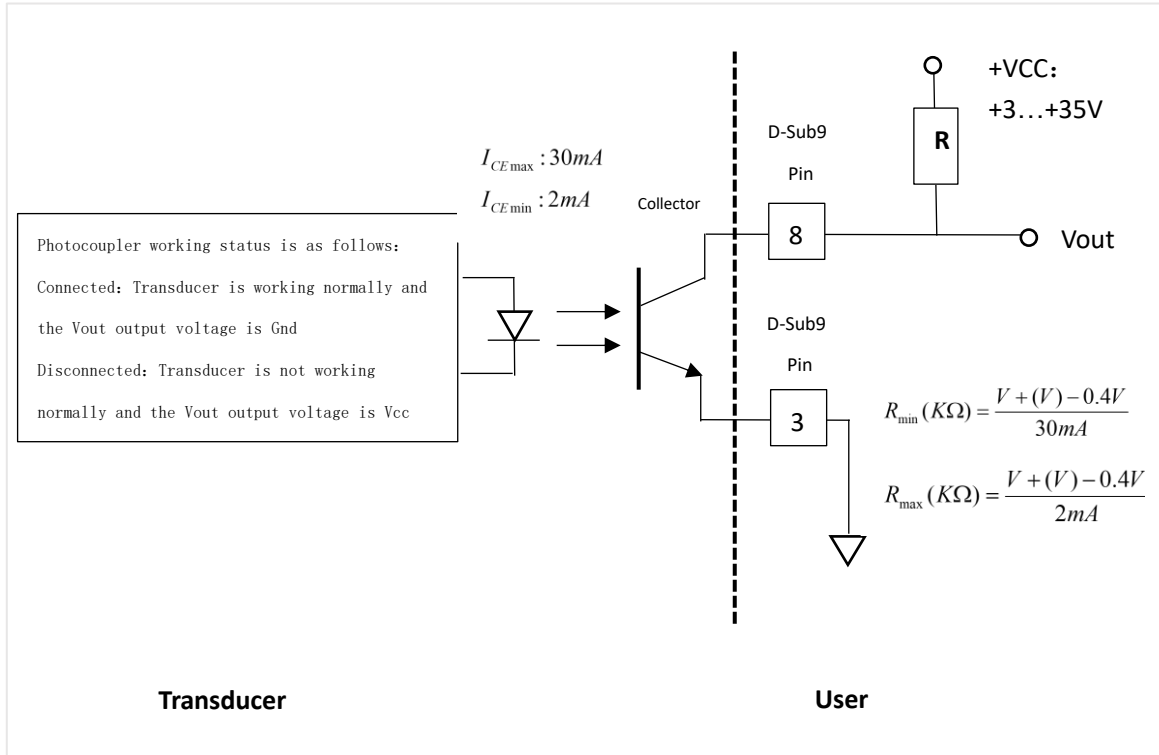

Fig A: Low level output when the transducer is operating normally

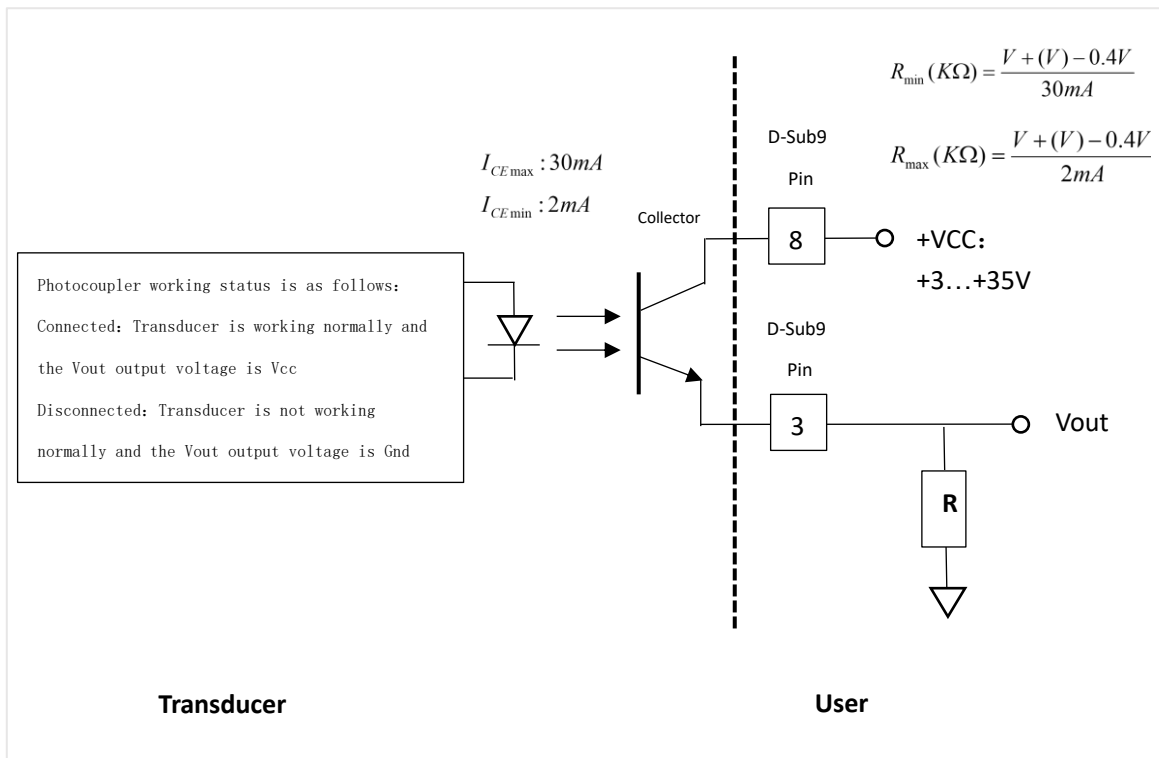

Fig B: High output when the transducer is operating normally



3. The output of the pin Vout in the optocoupler is related to the user-designed circuit, as shown in the following table.

Parameter	Vout	Description
Fig A	<0.2V	The transducer is working normally.
	Vcc	The transducer is working abnormally, i.e., in overload mode or abnormal power supply
Fig B	<0.2V	The transducer is working abnormally, i.e., in overload mode or abnormal power supply
	Vcc	The transducer is working normally.

Dimensions

Unit: mm

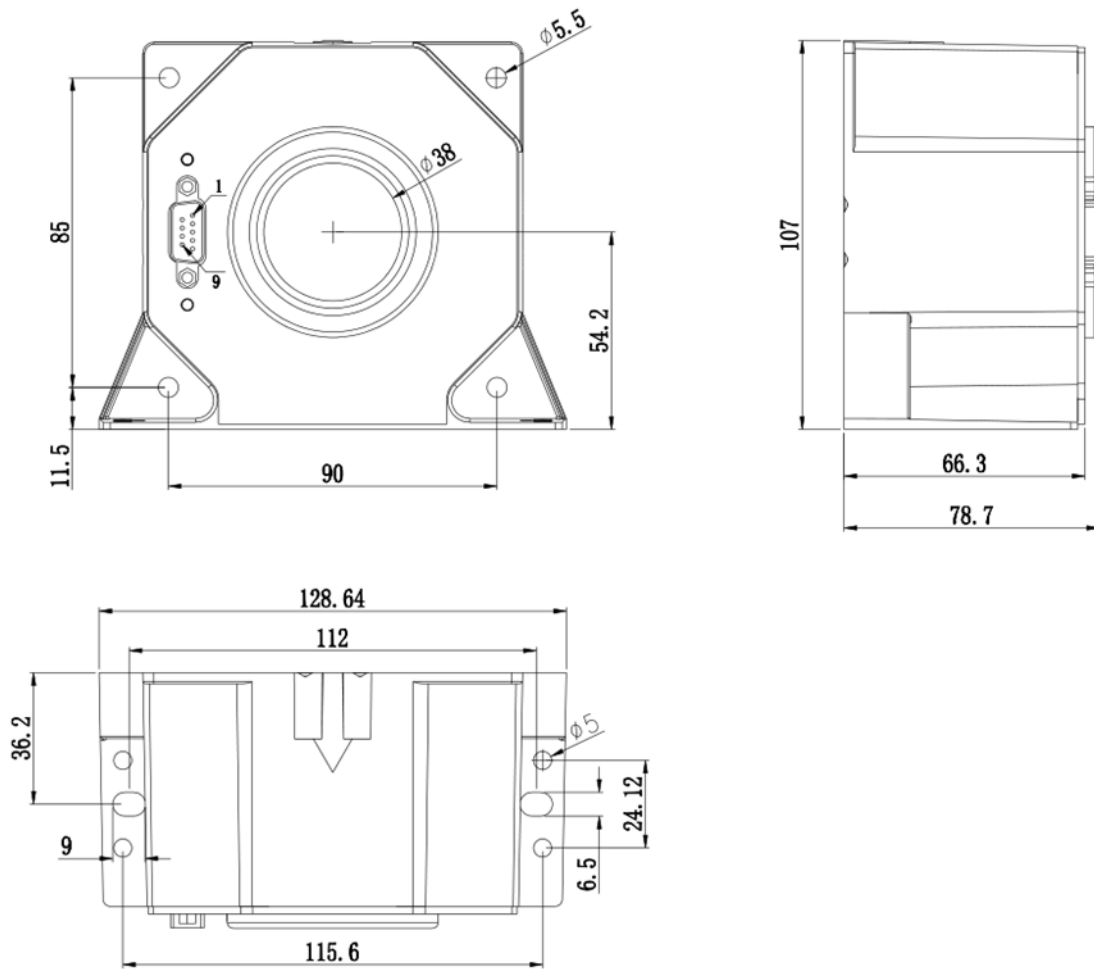

SHENZHEN HANGZHI PRECISION ELECTRONICS CO.,LTD

Add: Rm 531, Building B, Huayuan Hi-Tech Innovation Park,
Baoyuan Rd, Bao'an District, Shenzhen, China P.R.

Email: sales@hangzhiprecision.com

Technical Support: support@hangzhiprecision.com

Tel: +86 (0)755 8259 3440

Website: www.hangzhiprecision.com

